



A Century of Progress with Pride

January 3, 2017

Re: Waiting List Application

I am interested in the following programs and would like to be added to the waiting list (please check all programs of interest):

- Flood Mitigation Shared Cost Program
- Downspout Disconnection Program

Homeowner Name \_\_\_\_\_

Address \_\_\_\_\_

Phone \_\_\_\_\_

E-mail Address \_\_\_\_\_

**To be eligible for these programs, do not make any changes to the property at listed at the above address, prior to receiving City approval of your application(s).**

Please forward to the attention of the Engineering Department, City Hall, at 6700 W. 26<sup>th</sup> Street, Berwyn, IL 60402, [stormwater@ci.berwyn.il.us](mailto:stormwater@ci.berwyn.il.us) or fax 708-749-6593. Please check the City's website at <http://www.berwyn-il.gov/Flood%20Information>, for any updates on flood related items.

Feel free to contact the Engineering Department at any time with questions regarding these programs.

Sincerely,

Engineering Department, City of Berwyn

OFFICE USE ONLY

Date and Time received	Received by
------------------------	-------------



**A Century of Progress with Pride**

Re: Flood Mitigation Program Waiting List Now Open

Dear Homeowner,

The City Council passed a resolution adopting a Residential Flood Mitigation Shared Cost Program on November 12<sup>th</sup>, 2014. The goal of this program is to provide financial assistance to homeowners who install systems to protect their homes from sewer backup during a heavy rain event. This is a reimbursement program, in which the homeowners must first receive approval to take part in the program prior to installing a flood mitigation system. Improvements installed prior to approval are not eligible for reimbursement. Since this program has been adopted by the City Council, the waiting list is now open.

Please carefully review the attached Flood Mitigation Shared Cost Program Guidelines and FAQ sheet. If you wish to be placed on the waiting list for participation in this program, submit the attached form to the Engineering Department, at City Hall, [stormwater@ci.berwyn.il.us](mailto:stormwater@ci.berwyn.il.us) or fax 708-749-6593. Please check the City's website at <http://www.berwyn-il.gov/Flood%20Information>, for any updates on flood related items.

**To be eligible for reimbursement, do not install any flood mitigation device prior to receiving City approval of your application.**

If the homeowner is interested in the downspout disconnection program offered by the City, a preliminary inspection by the Engineering Department will be required prior to the disconnection of the downspouts.

Please feel free to contact the Engineering Department at any time with questions regarding this program.

Sincerely,

Engineering Department, City of Berwyn



# **Residential Flood Mitigation Shared Cost Pilot Program**

**OVERHEAD SEWER AND BACKFLOW PREVENTION**

January 13, 2017

## **Residential Flood Mitigation Shared Cost Pilot Program Guidelines**

### **Program Goals**

The Residential Flood Mitigation Shared Cost Pilot Program was established to provide financial assistance to homeowners who install systems to protect their homes from sewer backup during a heavy rain event. The program's intent is to offset a portion of the expense of modifying a building's plumbing system to prevent backflow when City sewers are at capacity and assistance to homeowners who desire to protect their home from flooding during a heavy rain event.

This is a reimbursement program, in which the homeowners must first receive approval to take part in the program prior to installing a flood mitigation system. Improvements installed prior to approval are not eligible for reimbursement.

To repair or modify building sewer systems, there are three (3) basic options available to the homeowner as follows:

1. Modification of the internal waste piping to direct the flow out of the building in a new OVERHEAD SEWER and the elimination of all gravity drainage below the basement floor (Figure 1),
2. Installation of a BACKFLOW PREVENTION VALVE and BYPASS PUMP on the building lateral in an underground vault installed outside of the building between the building and City sewer main (Figure 2), and
3. Installation of a BACKFLOW PREVENTION VALVE only, on the building lateral outside of the building between the building and City sewer main (Figure 2 without bi-pass pump).

Each of the above approaches has different costs, degrees of disruption and levels of

protection.

This Program is designed to assist homeowners in reducing the risk of basement flooding due to sewer backups. However, there is always a risk of a sewer backup as a result of unexpected sewer collapse, obstruction, power failure, extreme environmental or weather conditions or other unforeseen factors, as well as basement flooding due to seepage and other causes. Homeowners assume the risk of loss of any future property damage due to flooding.

Homeowners **are required** to disconnect roof drainage/downspouts and footing drain sump pumps from their sewer system as an integral component of this program except in specific hardship cases where an exemption may be granted by the City.

Prior to the disconnection of the downspouts, the homeowner will be required to schedule a preliminary inspection with the Engineering Department, if the homeowner is interested in the **downspout disconnection program** offered by the City. Downspouts previously disconnected will not be eligible for the downspout disconnection program.

Eligible homeowners may qualify for a 50% cost sharing, up to a maximum of \$3,500.00 for installing an overhead sewer system, a backflow prevention valve with a bypass pump or a backflow prevention valve only.

### **HOMEOWNER PROTECTION**

Modification of the plumbing in a building (in many cases) can prevent the backflow of sewage into below ground areas of buildings during times of an overloaded combined sewer system. Installation of pump(s), where required, to lift the building's lower level sewage above the street level will provide this positive protection.

In order to fully protect a basement from flooding, in addition to installing a flood mitigation system, homeowners should make sure foundation drains are operating properly to prevent seepage of ground water through walls below grade. (This

Program does not cover existing foundation drains, and the City will not test them for proper operation under this Program.) The homeowner has the responsibility for all testing, inspections and any corrective work that may become necessary.

Homeowners should also make sure their sump/ejector pump(s) operates reliably. The continuous operation of sump/ejector pump(s) is necessary for the proper functioning of overhead sewers, backflow prevention valves and foundation drains. The homeowner is responsible to check the operation of the pumps regularly. The homeowner is responsible for all testing, inspections and any corrective work that may become necessary after the improvements covered by this Program are installed. Homeowners should also install a battery backup system to provide protection in the event of power failure.

The homeowner owns the sewer service from the house to the sewer main, typically located in the center of the road. The homeowner should perform regular maintenance procedures on their sewer lateral line. Such items are use of root killer in the sewer service and regular sewer service and catch basin cleaning. Homeowners can also take part in the sewer line warranty program.

#### **ITEMS COVERED UNDER THIS PROGRAM**

This Program covers Flood Mitigation measures. The following are **Eligible** costs which may be covered as part of this program:

- Cost of location, excavation and exposure of the building sewer, including the support of existing structures, for reconnection to a new overhead sewer to the existing sewer line or for the installation of a clean-out for the purpose of lining the sewer lateral to the City's sewer main.
- Cost of a new pump pit, ejector pump and associated electrical and plumbing works needed to lift the drainage from basement plumbing fixtures to an overhead sewer or existing soil stack.

- Cost of trenching and concrete floor replacement.
- Cost of installing a backflow prevention valve with a bypass (new sump and ejector pump in an underground vault) and associated electrical and plumbing work.
- Cost of grass seeding or sod to restore disrupted landscape.
- New electrical panels and/or upgrading the house electrical supply to power a new sump pump(s).
- Applicable permit fees.

The following are **Non-Eligible** costs which will not be covered by this program:

- Battery backup system.
- Removal and replacement of interior basement walls and finishes.
- Use of materials not meeting the requirements of the City's Specifications or Codes.
- Ancillary homeowner improvements not necessary to provide sewer backup protection of the basement.
- Planting of new or replacement landscaping (bushes and trees) other than grass seeding or sod.
- Homeowner enhancements not necessary to provide sewage backup protection in below grade levels of buildings.
- Costs associated with disconnecting downspouts and roof drains from the City's sewer system.
- Expenses incurred prior to City approval of application packet.
- Inspection fees.

### **PROGRAM ELIGIBILITY**

This program is open to owner occupied single-family homes that are susceptible to sewer backup by way of a gravity sewer line. Single family is defined as both traditional single family homes as well as multi-family residences of 1-3 units where the owner occupies at least one unit. A property will be eligible for this program only once.

Applications will be received until the funds dedicated to this purpose have been expended, afterwards interested applicants will be put on a waiting list until funds are made available.

Homeowners will be considered ineligible if:

- Any unpaid taxes or water bills or other debt is due to the City.
- Any unpaid final judgments of liability from the office of Adjudication are due and owing.
- Any unpaid City liens are on any property owned by the applicant.
- Any outstanding Code violations exist that the homeowner has been advised of and had not corrected.
- The homeowner is not current on any other City obligations; or not in compliance with requirements of the City Code, including but not limited to multi-family licensing, alarm permitting or vacant building registration.

## **PROCEDURES**

The City will undertake this Flood Mitigation Shared Cost Program immediately to assist with flood prevention. The City reserves the right to modify the administration of the Flood Mitigation Program, as well as policies, procedures and rules adopted under this Flood Mitigation Program as a result of the information and experience compiled throughout the program.

The basic steps in the procedure for the overall program are as follows:

1. The homeowner establishes initial intent to participate in the Flood Mitigation Program by contacting the **Engineering Department**, in person or in writing at City Hall, [stormwater@ci.berwyn.il.us](mailto:stormwater@ci.berwyn.il.us) or fax 708-749-6593. The homeowner will provide their name, address, phone number and e-mail address on a form with the Engineering Department. The form can also be filled out and printed from the City's website at <http://www.berwyn-il.gov/Flood%20Information>



2. The plumbing inspector and/or Engineer will undertake the building inspections to establish the existing conditions and to determine if the property is eligible.

3. If the homeowner is not eligible, the Engineer will notify the homeowner of the reason for the ineligibility. If the reason for the ineligibility is due to an outstanding debt, judgment or code compliance issue, the homeowner will be allowed to satisfy those obligations, come into compliance with the City Code and re-apply. For purposes of determining priority, the homeowner's place in line will be based upon the date of reapplication.

4. After being deemed eligible, the homeowner shall give final notice of intent to participate in the program by signing and returning a completed application packet. The application consists of:

- a) Completed Application Form.
- b) A detailed proposal(s) from an Illinois licensed plumbing contractor(s), which includes technical information on materials, pumps, valves, electrical panels, etc. that will be used on the improvement. The City encourages homeowners to obtain at least three estimates from qualified contractors for this work.

5. The City reviews application packet and formally replies to homeowner of approval or denial. The City's response will identify the portions of the proposed improvement which are eligible and which are not eligible as well as the maximum amount of eligible cost sharing reimbursement.

6. The homeowner shall then authorize the contractor to do the work by executing the contract approved by the City.

7. The contractor shall follow all project requirements, obtain the permit for

construction (permit fees will be waived for items qualifying under this program) and schedule City Inspection visits (inspection fees still apply) as required during construction. The City shall inspect the improvement, maintain records of inspections and approve the final installation.

8. Upon completion of the work, the homeowner shall submit the Request for Reimbursement form, accompanied by the following:

- a) Proof of payment.
- b) Certifications from the contractor that work was completed.
- c) Certification from the City Inspector that the work was completed in accordance in with City Codes and passed final inspection.

9. The Engineer shall review the Request for Reimbursement form, certify the eligible improvement costs and requested reimbursement amount, and forward the approved Request for Reimbursement to the City Finance Department.

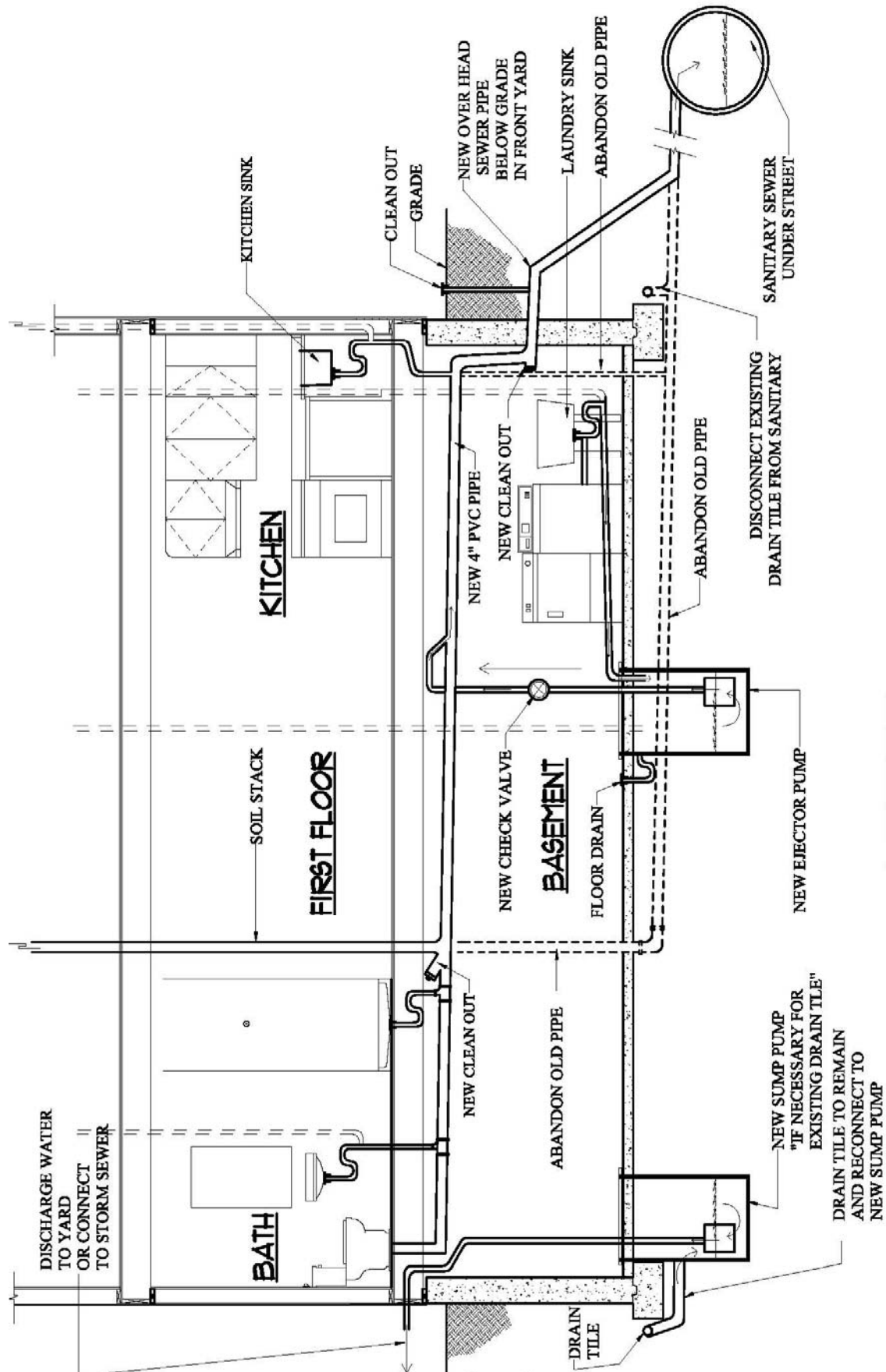
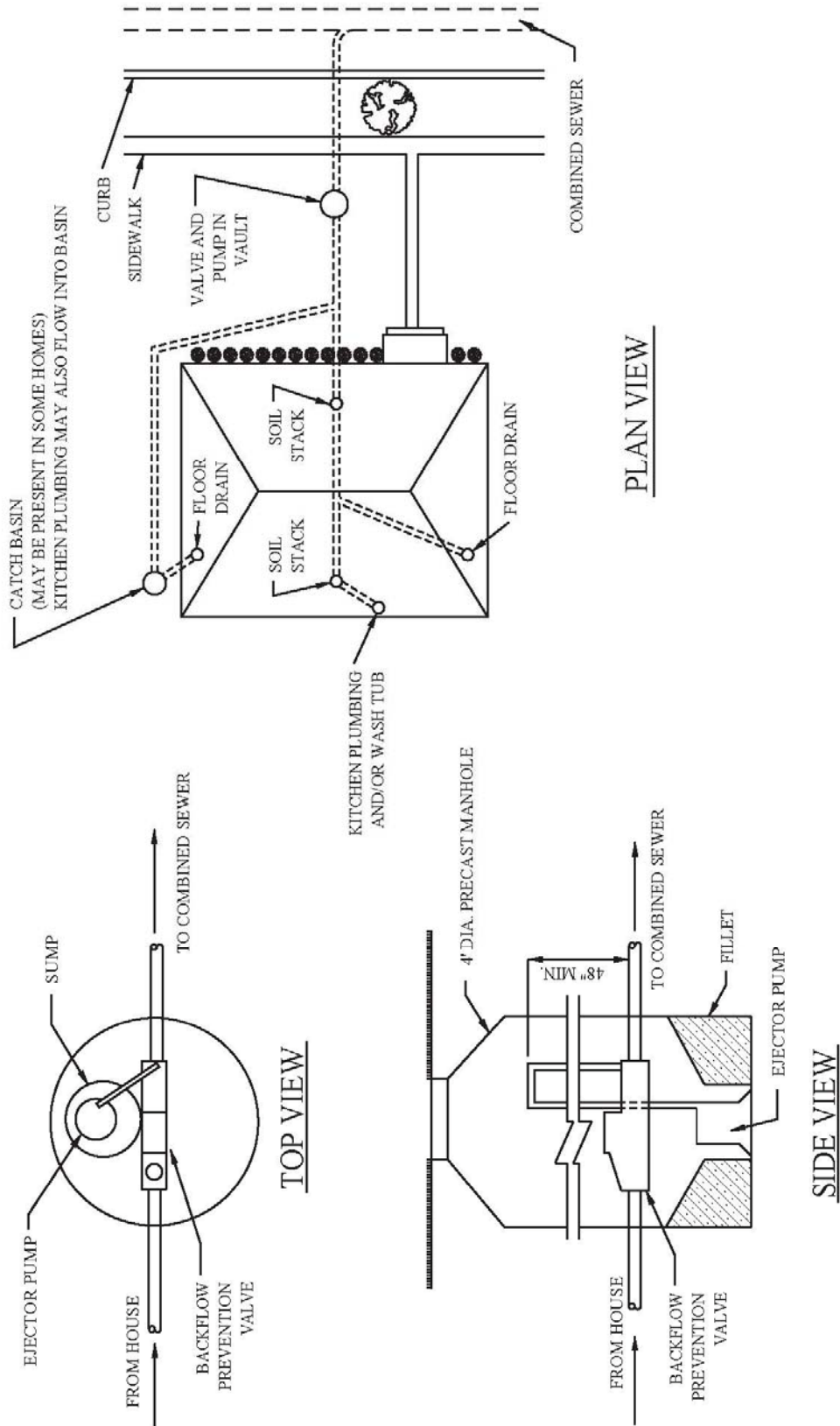

Figure 1



**Figure 2**

**EXAMPLE OF A TYPICAL INSTALLATION OF  
A BACKFLOW PREVENTION VALVE**



## Residential Flood Mitigation Shared Cost Program

### Frequently Asked Questions

1. What types of improvements are eligible for funding?
  - The installation of Overhead Plumbing
  - The installation of a Backflow Prevention Valve
  - The installation of a Backflow Prevention Valve w/Bypass Pump
  
2. What is the cost sharing available to residents of single family homes?
  - \$50% of costs up to \$3,500 maximum.
  
3. Who is eligible?
  - Owner occupied single-family homes. Single family is defined as both traditional single family homes as well as multi-family residences of 1-3 units where the owner occupies at least one unit.
  
4. How do I apply?
  - Directions for applying are found under the procedures section of the Program Guidelines. More information can be found on the City's website at <http://www.berwyn-il.gov/Flood%20Information>
  
5. Can I start the work now?
  - No, in order to be eligible for reimbursement, the homeowner must receive final approval from the City.
  
6. What are eligible costs for reimbursement?
  - Cost of location, excavation and exposure of the building sewer, including the support of existing structures, for reconnection to a new overhead sewer to the existing sewer line or for the installation of a clean-out for the purpose of lining the sewer lateral to the City's sewer main.



## Residential Flood Mitigation Shared Cost Program

### Frequently Asked Questions

- Cost of a new pump pit, ejector pump and associated electrical and plumbing works needed to lift the drainage from basement plumbing fixtures to an overhead sewer or existing soil stack.
  - Cost of trenching and concrete floor replacement.
  - Cost of installing a backflow prevention valve with a bypass pump (and associated electrical and plumbing work).
  - Cost of grass seeding or sod to restore disrupted landscape.
  - New electrical panels and/or upgrading the house electrical supply to power a new sump pump(s).
  - Applicable permit fees.
7. Who Will Administer the Program?
- The City's plumbing inspector and/or Engineer will do all the inspections for installation.
  - Permits will be issued through the building department prior to construction.
  - The Engineer will approve payments once renovations and inspections are finalized.
8. What Information Must Be Submitted as Part of Application?
- A completed application.
  - A contractor's proposal including sketch of existing plumbing and proposed improvements.
  - Complete and sign the agreement between the homeowner and City.
9. Can I e-mail or fax my application?
- Yes. Forms can be mailed, hand delivered, e-mailed or faxed to the Engineering Department at 6700 W. 26th Street, Berwyn, IL 60402. The e-mail address is [stormwater@ci.berwyn.il.us](mailto:stormwater@ci.berwyn.il.us) and the fax number is 708-749-6593.



## Residential Flood Mitigation Shared Cost Program

### Frequently Asked Questions

#### 10. How Does Homeowner Obtain Reimbursement from City?

- The Request for Reimbursement form must be completed.
- The homeowner will present a paid invoice with proof of payment from the contractor to the City with detailed breakdown of charges and present final approved inspection report signed off by City staff.
- Reimbursements will be returned within 30 days of receiving the reimbursement form, granted that all work is approved and complete.

#### 11. How will I know that you received my application?

- Applicants will be notified within two business days that their application was received. Notification will be made by the same means that the application was submitted.

#### 12. Miscellaneous Items

- Work must be performed by an Illinois licensed plumber.
- Downspouts must be disconnected in order to participate in program.
- For the downspout disconnection program offered by the City, contact the Engineering Department for a preliminary inspection prior to disconnection.
- For more information e-mail the Engineering Department at [stormwater@ci.berwyn.il.us](mailto:stormwater@ci.berwyn.il.us)